

Smart String Inverter (SUN2000-60KTL-HV-D1-001)



Smart

- 4 MPPTs for versatile adaptations to different layouts
- 8 strings intelligent monitoring and fast trouble-shooting
- Power Line Communication (PLC) supported
- Smart String I-V Diagnosis supported

Safe

- DC disconnect integrated, safe and convenient for maintenance
- Type II surge arresters for both DC and AC
- Ground fault protection
- Residual Current Monitoring Unit (RCMU) integrated inside

Efficient

- Max. efficiency 99.0%, European efficiency 98.8%
- 800V output voltage and decrease 75% AC wire loss versus 400V
- Without N Line and save more AC cable

Reliable

- No need for external fans with natural cooling technology
- Protection rating of IP65

Efficiency Curve

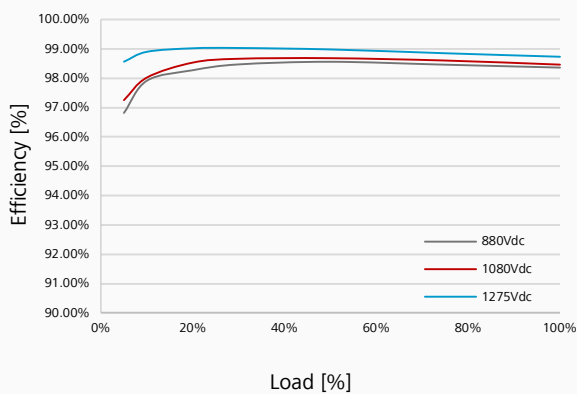

Circuit Diagram

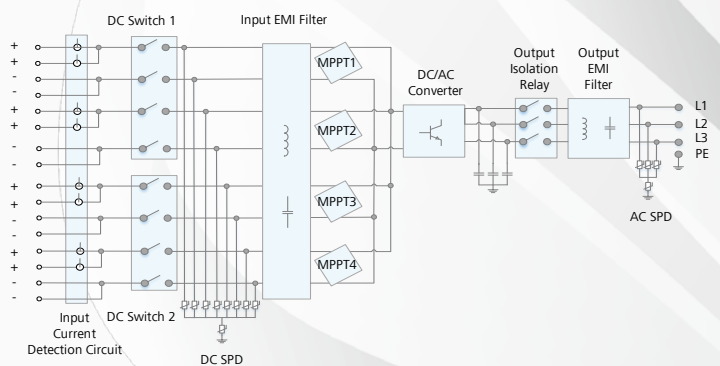

SUN2000-60KTL-HV-D1-001

Smart String Inverter (SUN2000-60KTL-HV-D1-001)



Technical Specifications	SUN2000-60KTL-HV-D1-001
	Efficiency
Max. Efficiency	99.0%
European Efficiency	98.8%
	Input
Max. DC Usable Power	67,300 W
Max. Input Voltage	1,500 V
Max. Current per MPPT	22 A
Max. Short Circuit Current per MPPT	30 A
Min. Operating Voltage / Start Input Voltage	600V / 650V
MPPT Operating Voltage Range	600 V ~ 1,450 V
Rated Input Voltage	1,080 V
Max. Number of Inputs	8
Number of MPP Trackers	4
	Output
Rated AC Active Power	60,000 W
Max. AC Apparent Power	66,000 VA
Max. AC Active Power (cosφ=1)	66,000 W
Rated Output Voltage	800V, 3W+PE
Rated Output Current	43.3 A
Rated AC Grid Frequency	50 Hz / 60 Hz
Max. Output Current	48 A
Adjustable Power Factor	0.8 LG ... 0.8 LD
Max. Total Harmonic Distortion	< 3%
	Protection
Input-side Disconnection Device	Yes
Anti-Islanding Protection	Yes
AC Overcurrent Protection	Yes
DC Reverse-Polarity Protection	Yes
PV-array String Fault Monitoring	Yes
DC Surge Arrester	Type II
AC Surge Arrester	Type II
Insulation Detection	Yes
Residual Current Monitoring Unit	Yes
	Communication
Display	LED Indicators
RS485	Yes
USB / Bluetooth + APP	Yes
Power Line Communication (PLC)	Yes
	General
Dimensions (W×H×D)	930 × 600 × 270 mm (36.6×23.6×10.6 inches)
Weight	62 kg (136.7 lb.)
Operation Temperature Range	-25 °C ~ 60 °C (-13°F ~ +140°F)
Cooling	Natural Convection
Max. Operating Altitude	4,000 m (13,123 ft)
Relative Humidity	0 ~ 100%
DC Connector	Amphenol UTX
AC Connector	Waterproof PG Terminal + OT Connector
Protection Rating	IP65
Topology	Transformerless